

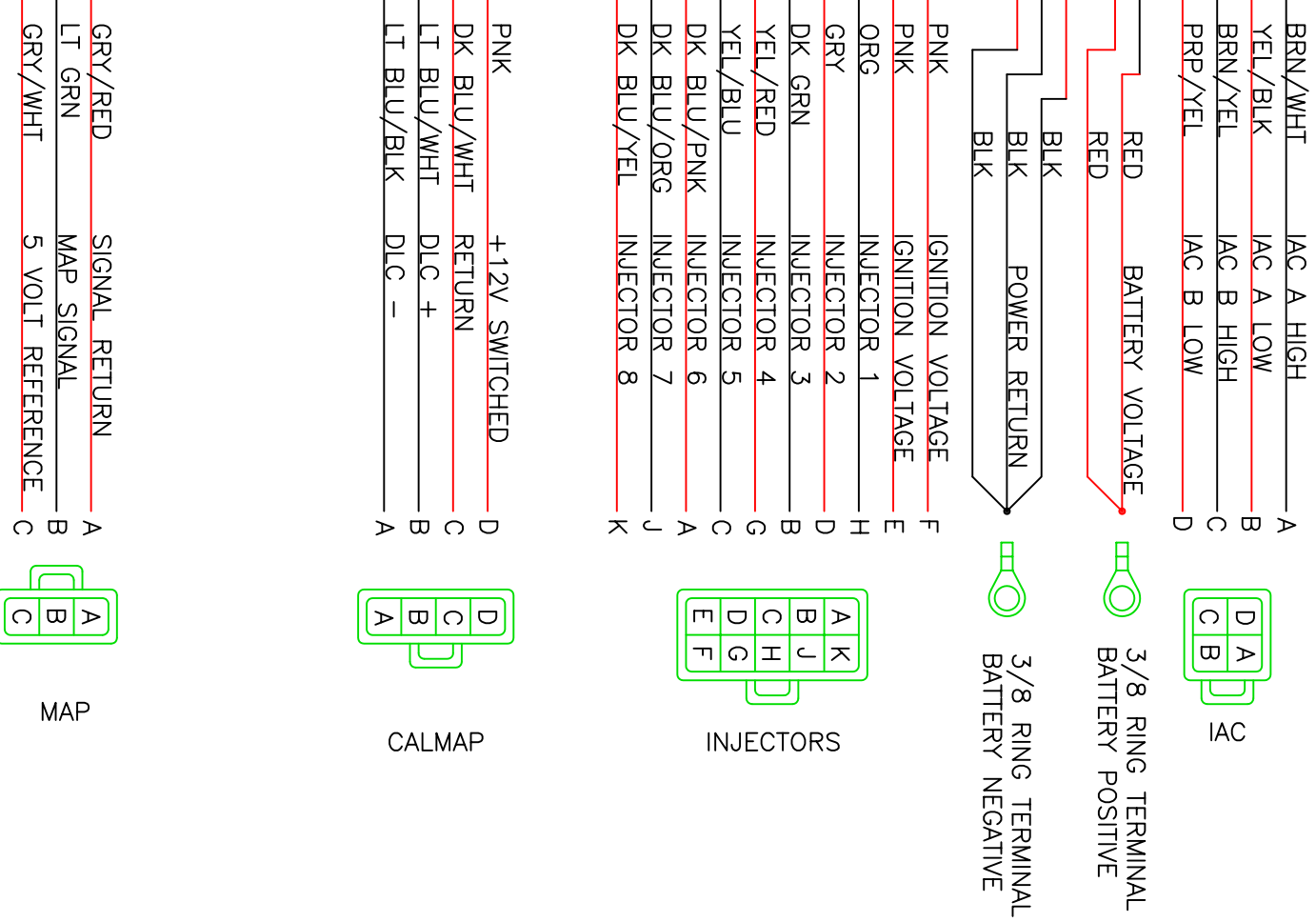

ECM CONNECTORS

Y12Y3	X12X3	W12W3	T12T3	S12S3	R12R3	P12P3	N12N3	M12M3	L12L3
K1K2K3	J1J2J3	H1H2	G2G3	E1E2	D1D2D3	C1C3	B1B3	A1A3	

K2	EST/POINTS	DK BLU
K1	BYPASS	WHT
H1	ESC	PRP
L3	IGNITION VOLTAGE	PNK
P2	IAC PIN A HIGH	BRN/WHT
P1	IAC PIN A LOW	YEL/BLK
R2	IAC PIN B HIGH	BRN/YEL
R1	IAC PIN B LOW	PRP/YEL
M1	BATTERY VOLTAGE	RED
S3	FUEL PUMP RELAY	PNK/BLK
R3	FAN RELAY	TAN/YEL
Y1	POWER RETURN	BLK
Y2	POWER RETURN	BLK
Y3	POWER RETURN	BLK
W2	INJECTOR 1	GRY
X2	INJECTOR 2	DK GRN
S2	INJECTOR 3	YEL/RED
W1	INJECTOR 4	YEL/BLU
P1	INJECTOR 5	DK BLU/PNK
N1	INJECTOR 6	DK BLU/ORG
S1	INJECTOR 7	DK BLU/YEL
L1	INJECTOR 8	LT BLU/WHT
L1	HEGO +	PNK/BLU
E2	SIGNAL RETURN	GRY/RED
A1	MAP SIGNAL	LT GRN
E1	5 VOLT SIGNAL	GRY/WHT
B1	TPS	BRN
D1	IAT	TAN/WHT
C1	ECT	TAN
A3	CKP+/REFERENCE	BLK
B3	CKP-	CLR
J2	SIGNAL RETURN DLC	DK BLU/WHT
C3	CAM+	BLK
D3	CAM-	CLR
N3	SIGNAL RETURN	BLK/WHT
G3	4TH GEAR	LT BLU/PNK
T3	NOS 1	LT BLU/ORG
W3	NOS 2	LT GRN/YEL
P3	MIL	WHT/BLK
N2	DLC-	LT BLU/BLK
D2	MST	LT BLU
M2	AUX INPUT 2 (STI)	LT GRN/ORG
J3	AUX OUTPUT 2 (SHIFT)	LT WHT
K3	AUX INPUT 1 (STAGE)	YEL/GRN
M3	IGNITION +12V DLC	PNK
X3	CASE GROUND	BLK
G2	AUX OUTPUT 1 (ACC)	YEL/LT BLU
H2	TCC RELAY	LT BLU/BLK
N2	NOS ENABLE 1	LT GRN/BLK
J1	NOS ENABLE 2	LT GRN/RED

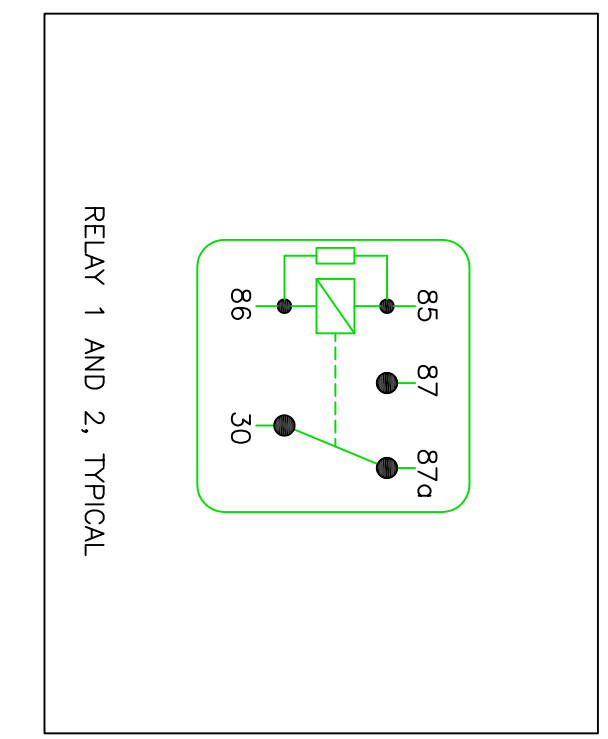
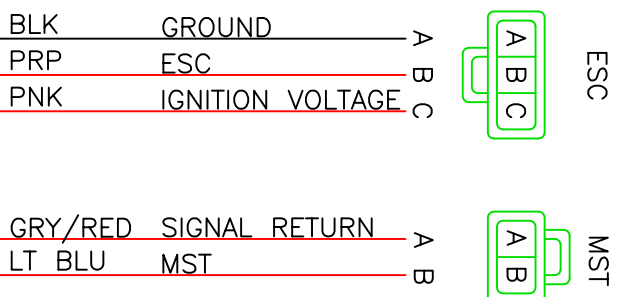
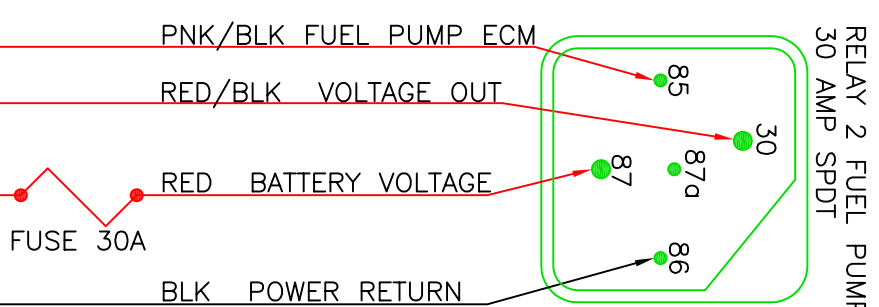
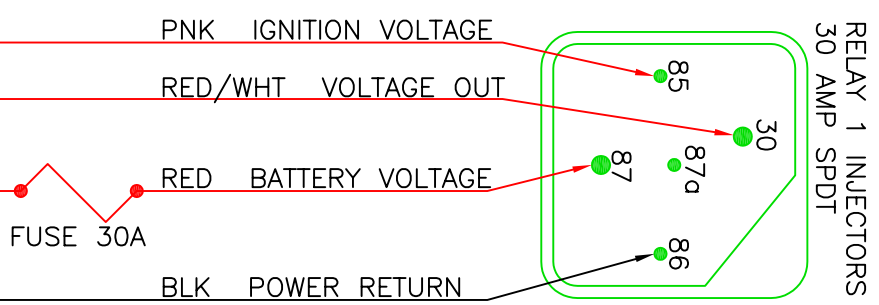
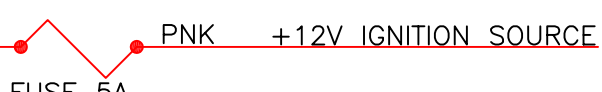
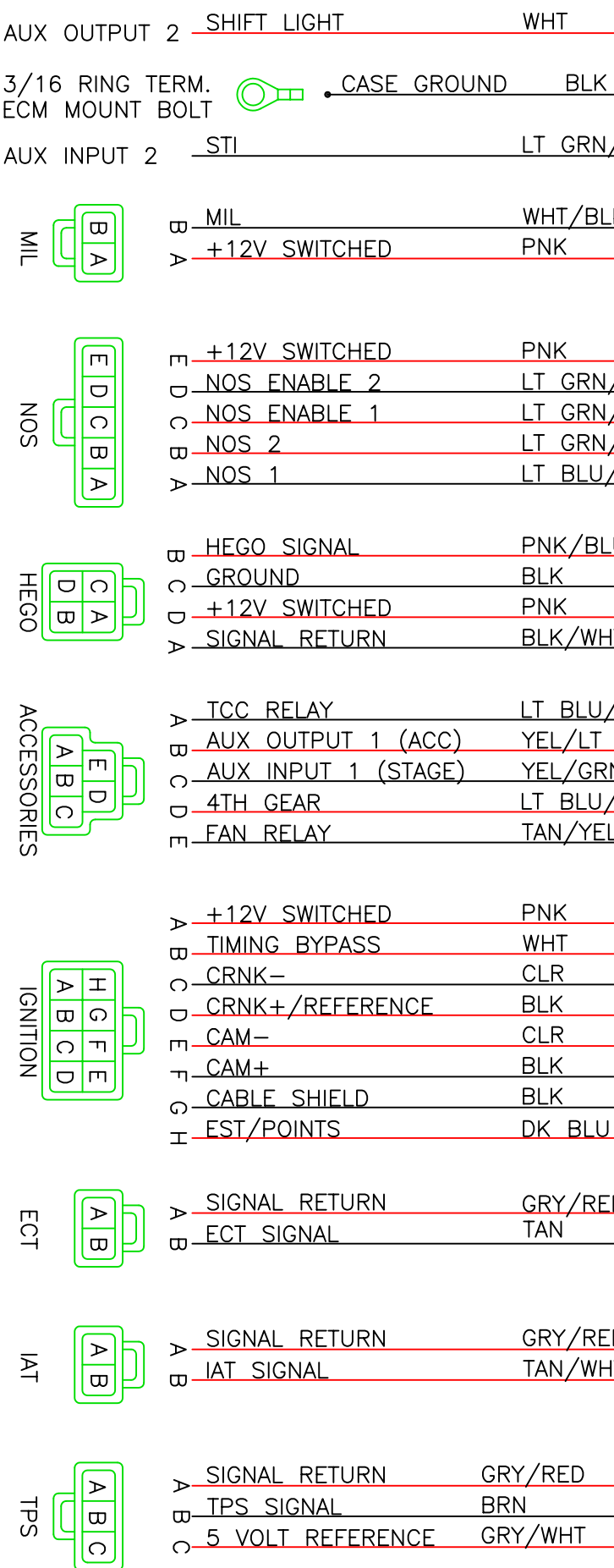

WIRING SCHEMATIC, CHEVY AND GN MAIN HARNESS
REV B./010705

RED AND BLACK WIRE COLORS ARE FOR VIEWING CLARITY ONLY AND DO NOT INDICATE ACTUAL WIRE COLOR

ALL CONNECTORS VIEWED FROM WIRE SIDE

ALL RIGHTS RESERVED. THIS DOCUMENT AND THE PROPRIETARY INFORMATION CONTAINED HEREIN IS THE EXCLUSIVE PROPERTY OF D.F.I. AND MAY NOT BE COPIED, REPRODUCED OR DISCLOSED TO THIRD PARTIES EXCEPT UPON AND IN ACCORDANCE WITH PRIOR WRITTEN PERMISSION OF D.F.I.